

# SPECIFICATIONS

## MEASUREMENTS

Lamps	Metal halide 4 x 1,000 W
Generator	Brushless 60 Hz, 6.0 kW
Engine	Kohler Diesel 10.7 hp
Receptacles	One GFI duplex 20 A / 120 V
Fuel capacity	45 gal (170 L)
Wheel size	13 in (33 cm)
Axle rating	2,200 lbs (998 kg)
Tongue weight travel position	203 lbs (92 kg)
Total weight no fuel	1,461 lbs (663 kg)

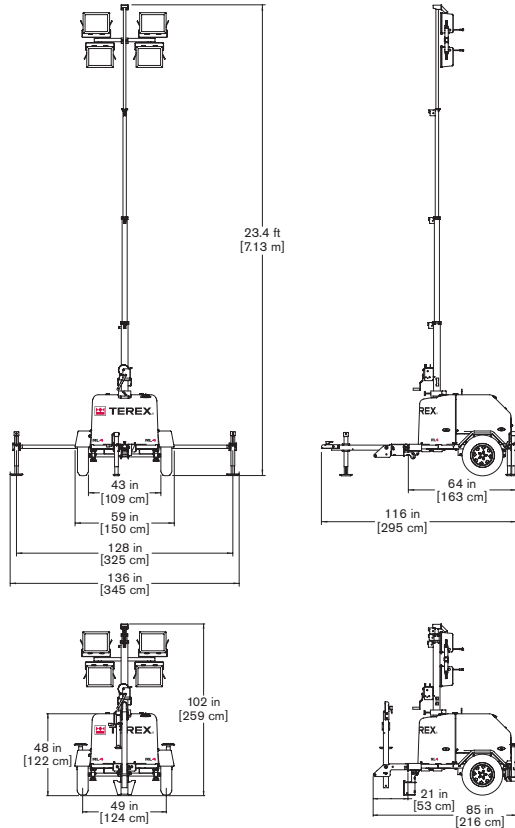

Notice: Metal halide lamp bulbs contain mercury (Hg). Dispose of lamp bulbs according to local, state and federal laws.

## FEATURES

Durable 23 ft / 7 m vertical mast with manual self braking winch, mast brake and 359 degree mast rotation for quick setup and light positioning

4x1000w square cast aluminum metal halide lamps, Kohler 10.7hp engine, 45 gal / 170 L fuel tank and 6kW generator provide up to 90 hours of run time

Efficient design layout allows up to 17 units per truckload, with fork pockets and lifting eye for quick loading and unloading

Rust proof polymer covers provides ample access for service and maintenance, with locking tabs for security

Platform to access lights and fold up tongue for transport

Standard engine protection includes high water temperature and low oil auto shutdown

DOT approved run, stop and turn lights, standard

Telematics ready



*The Lifting Professionals*

Bolingbrook, IL  
(630) 972-9199

South Holland, IL  
(219) 972-9199

[Click Here to Request a Quote](#)

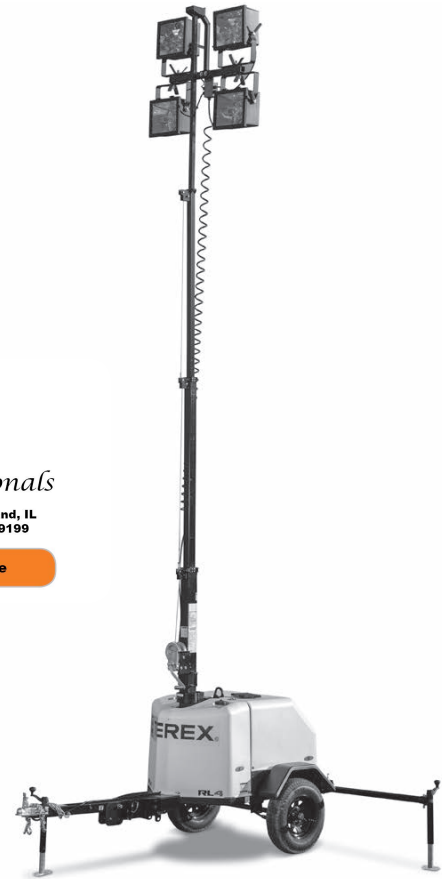

## CHASSIS OPTIONS

Genie® branding and blue paint

Dome light with switch, 12V

Export racking and preparation

Multiple hitch configurations

## ENGINE OPTIONS

6 kW, 60 Hz generator with 13.6 hp Kubota® diesel

7 kW, 50 Hz generator with 13.6 hp Kubota® diesel

8 kW, 60 Hz generator with 13.6 hp Kubota® diesel

Positive air shutdown

Fuel/water separator filter

Fuel/water separator with fuel line heater

Autostart

One T/L 30A/240V receptacle

## TOWER OPTIONS

4 horizontally mounted lights, spun aluminum housing

Electric winch

## COLD WEATHER OPTIONS

800 CCA battery

Battery heater blanket

Low temperature coolant mix

Engine block heater



**WORKS FOR YOU.™**

[www.genielift.com](http://www.genielift.com)

Effective Date: June, 2015. Product specifications and prices are subject to change without notice or obligation. The photographs and/or drawings in this document are for illustrative purposes only. Refer to the appropriate Operator's Manual for instructions on the proper use of this equipment. Failure to follow the appropriate Operator's Manual when using our equipment or to otherwise act irresponsibly may result in serious injury or death. The only warranty applicable to our equipment is the standard written warranty applicable to the particular product and sale and we make no other warranty, express or implied. Products and services listed may be trademarks, service marks or trade names of Terex Corporation and/or their subsidiaries in the USA and many other countries. Terex, Genie and Works For You are trademarks owned or licensed by Terex Corporation or its subsidiaries. All other trademarks are property of their respective owners. © 2015 Terex Aerial Work Platforms. RL4 0210F Part #109044

Genie United States  
18340 NE 76th Street  
P.O. Box 97030  
Redmond, Washington 98073-9730  
Telephone +1 (425) 881-1800  
Toll Free in USA/Canada +1 (800)-536-1800  
Fax +1 (425) 883-3475

Distributed By:



**TEREX**®

**WORKS FOR YOU.**™