

CX50



KOMATSU[®]



The Forklift With Proven Ability.™

PNEUMATIC TIRE FORKLIFTS

8,000 – 11,000 LBS. CAPACITY | GAS, LPG & DIESEL

"Reducing Total Operating Costs" with Komatsu Innovative Technologies

The fusion of advanced engine technologies and Komatsu's unique hydraulic system enables the new CX50 series to achieve a significant reduction in total operation costs and facilitates superior working performance. Our innovative machines challenge the conventional concept of the forklift.

Diesel Engine Truck

An optimum engine achieves lower fuel consumption and higher performance.

Gasoline Engine Truck

A fully electronically controlled engine with a 3-way catalytic system conforms to the latest emission regulations.

Komatsu's Hydraulic System and the NEW Diesel Engine reduce Fuel Consumption



In order to minimize hydraulic loss and reduce the engine load, the new CX50 Series adopts the CLSS hydraulic system, a proven technology of Komatsu construction machines. The compact 3.3-liter diesel engine features superior performance and achieves up to a 20% reduction in fuel consumption.

Fuel Consumption
Max. 20% savings

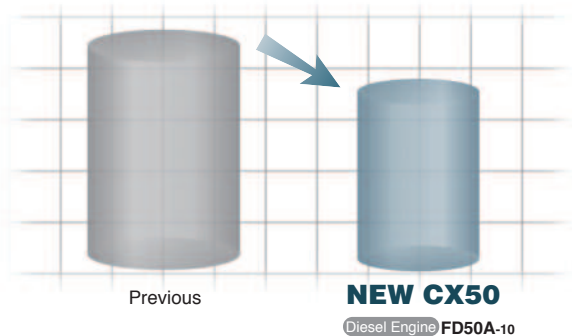

Komatsu tested data, comparison with FD50A-8. The results may vary depending on conditions.

The "CLSS" contributes to Lower Fuel Consumption and Higher Productivity

The hydraulic load is automatically detected and only the appropriate amount of oil is supplied via a variable displacement pump. This system eliminates the loss of hydraulic oil and reduces the engine load.

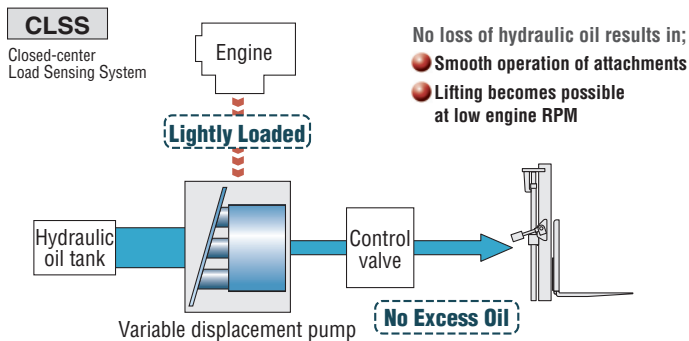

Previous hydraulic system

A fixed amount of oil is supplied from the gear pump and excess oil is returned to the hydraulic oil tank. This resulted in increased engine load.

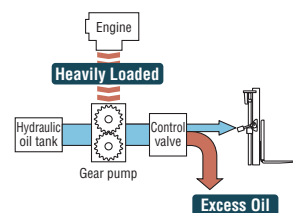

Greatly Reduced Total Operating Costs (Diesel)

The standard sealed wet disc brake system is designed to withstand 10,000* hours of operation without maintenance, thereby eliminating downtime and the added maintenance costs of frequent brake shoe replacements. The engine oil replacement interval has been extended to 500 hours, which reduces oil costs. The reduced maintenance costs and significant fuel savings provides a total operating cost reduction of approximately 14% over eight years of usage.

*A periodic check and oil replacement are necessary.

Running cost (Accumulated costs for 8 years)

Assuming FD50A-8 as 100%;

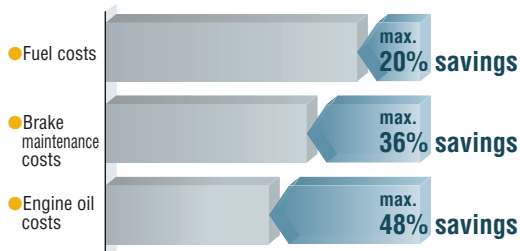

Total operating cost (*Image)

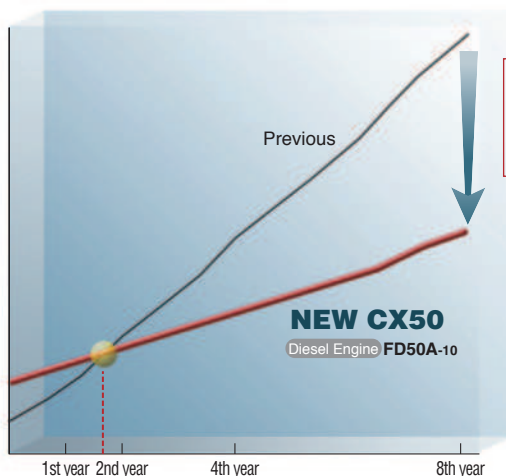

Total operating cost
Approx. 14% savings
(8 years)

Komatsu tested data, Comparison with FD50A-8 model. Operation hours: 5 h/day, 25 days/month (Total: Approx. 1500 h/year), Maintenance intervals to manufacturer's recommendation. The results may vary depending on conditions.

Advanced Technology Offers Reduced CO₂ Emissions (Diesel)



The diesel models feature the Komatsu SAA4D95LE-5-A engine in combination with the efficient CLSS hydraulic system, enabling them to reduce annual CO₂ emissions by approximately 7.2 tons.

Annual CO₂ emissions
About **7.2 tons** reduction

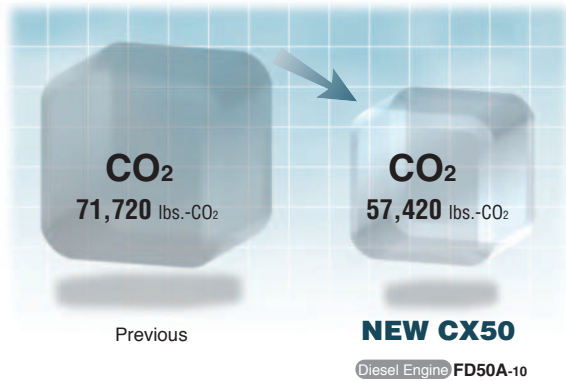

Komatsu tested data, Comparison with FD50A-8 model. The results may vary depending on conditions.

An Advanced Diesel Engine conforms to the Latest Emission Regulations

Low fuel consumption and low environmental impact are enabled by elimination of excess combustion and the use of the combined technologies of the high pressure common rail system, electronic control system, new combustion system and air-to-air charge air cooling system.

EPA Tier 3 / EU Stage IIIA Emission Compliant

ecot3
ecology & economy - technology 3

Komatsu SAA4D95LE-5-A

Displacement:

3.3 liter

Rated Output:

92.5 hp @ 2,250 rpm

Maximum Torque:

237 lb. ft. @ 1,600 rpm



Gasoline Engine with a 3-Way Catalytic System

An electronically controlled engine with a 3-way catalytic system provides for a cleaner work environment.

EPA and CARB Emission Compliant

EBT-TB45-1A*

Displacement:

4.5 liter

Rated Output:

83.8 hp @ 2,400 rpm

Maximum Torque:

201 lb. ft. @ 1,600 rpm

* EBT-TB45-1A for Gasoline.



Superior "Productivity" and "Reliability" Satisfy Demanding Operational Needs



Durable Wet Disc Brakes to Withstand Severe Conditions

The wet disc brake system is sealed with oil to block dust penetration, providing durable, water resistant and fade resistant characteristics. Smooth, stable braking provides "Productivity" and "Reliability" in demanding operations.



A Cooling System to achieve Increased Braking Stability

The oil in the wet disc brake system is circulated through the brake oil cooler. This mechanism ensures stable braking under a heavy work load and prevents deterioration of the braking force that could be caused by raised oil temperatures.

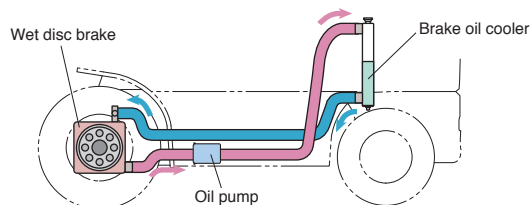

A Cushioning Valve improves the Braking Feel

Komatsu's unique cushioning valve enables controlled braking force that precisely reflects the pressure on the brake pedal. The braking behavior is improved, and the operator has greater control.

- **Steady braking is always achieved.**
- **Overheating of the brakes is prevented.**
- **Rough stopping is prevented when braking.**
- **Downtime and maintenance costs are reduced.**

First-class Productivity is achieved

First-class Cycle Time

The diesel models utilize a compact 3.3-liter engine with the advanced CLSS hydraulic system to achieve high productivity and first class cycle times. The gasoline engine model is also designed to achieve higher productivity.

- **The NEW CX50 Series achieves high productivity equivalent to the previous CX Series.**

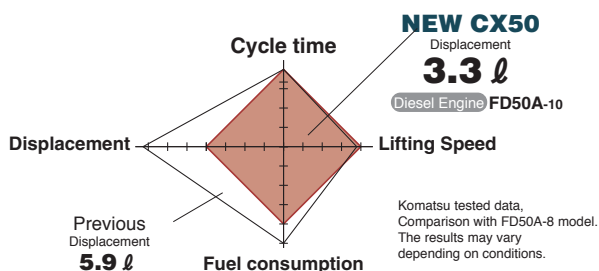

- **Lifting Speed (Loaded)**

Diesel Engine FD50A-10

92.5 fpm

Gasoline Engine FG50A-10

86.6 fpm

- **Traveling Speed (Unloaded)**

Diesel Engine FD50A-10

15.5 mph

Gasoline Engine FG50A-10

15.2 mph

The CLSS enables Lifting at Low Engine RPMs

The CLSS makes it possible to lift the load for fine height adjustment without increasing the engine speed.

Reduced engine RPM in the following cases:

- **Fine adjustment of fork height**
- **Lifting fork tips before starting**
- **Fine adjustment for side shifting**

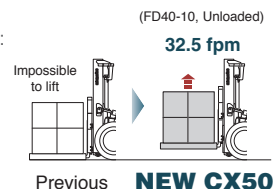

The CLSS enables advantages such as:

- **Smooth traveling during hydraulic operation**
- **Superior productivity when fitted with attachments**
- **Fuel consumption reduced by up to 20% (Diesel)**

Fully Hydrostatic Power Steering for Superb Maneuverability

The Fully Hydrostatic Power Steering (FHPS) system facilitates fully stationary steering as well as switchback operations using the small diameter steering wheel. The system has a superior response capability so that the operator can maneuver easily with a load even in a tight area.

Excellent Durability To Handle Demanding Work Cycles

Rugged Design with High Rigidity

The highly rigid mast, frame, and front and rear axles ensure outstanding reliability even when performing heavy-duty work.

[Mast]

A heavy mast rail profile for excellent rigidity.

[Frame]

Increased thickness for greater durability of the counterweight mounting section.

[Front axle]

New field proven design adopted from Komatsu wheel loader construction equipment.

[Rear axle]

The durability of the Power Steering cylinder is improved.

Improved Reliability in the Hydraulic and Electrical Systems

The main hydraulic pipe connectors use O-ring face seals to reduce the possibility of leaks. Waterproof connectors are used in the main harnesses and the system controller in order to provide higher resistance to water and dust. Hydraulic and electrical piping systems are in separate configurations to improve reliability and ease of service.

Engine Protection Systems to Keep the Engine in the Best Operating Condition

The electronic engine controls upgrade the performance of the engine protection system (fail-safe functions).

- **Trouble diagnosis:**
Engine malfunctions are automatically detected and an alarm lamp blinks.
- **Overheating prevention (Diesel):**
The engine output and RPMs are reduced when the coolant temperature is high.
- **Automatic engine warm-up (Diesel):**
The RPMs are accelerated to warm up the engine at low temperatures.
- **Automatic air pre-heating (Diesel):**
The engine is automatically pre-heated when starting at low temperatures.



Engine failure indicator



The Compact 11,000 lb. model

The compact 11,000 lb. model features a shorter wheelbase and better maneuverability while maintaining the power and speed capable of achieving high productivity.



Advanced Design in Pursuit of "Safety and Comfort"

Effective Risk Reduction Mechanisms

KOPS Plus - "Komatsu Operator Presence System"

The CX50 features KOPS Plus to protect people and equipment if the operator leaves the seat. If the seat is vacant for more than three seconds, KOPS Plus automatically locks out all lift, lower, tilt and travel functions. The operator must return to the seat to unlock the system. A flashing yellow warning light alerts the operator when KOPS Plus is activated. In addition, the forks cannot be lowered with the key in the off position.

*The traveling interlocking function only disengages traction and does not automatically apply the brakes.
* KOPS Plus - "Komatsu Operator Presence System": ISO3691-1 compliant



KOPS Plus Hydraulic Lock Indicator



KOPS Plus is activated when the operator leaves the seat for more than three seconds.

Parking Brake Alarm

If the operator fails to engage the parking brake, an alarm will sound.



A double acting type brake lever prevents mishandling

An Optional Wide Angle Center Mirror enables an Easy View Rearward



A Neutral Safety Function to Prevent an Inadvertent Start

The engine cannot be started unless the F-R switch is in the neutral position.



Neutral indicator for at-a-glance information

ANSI/ITSDF B56.1 Compliant Enhanced Overhead Guard for Operator Protection and

A Safety Mechanism that prevents starting the engine unless the brake pedal is depressed



Secure Operation Controls Improve Operator Work Efficiency

Secure Lever Controls with Minimum Movement



Finger-tip operation with the electric F/R lever

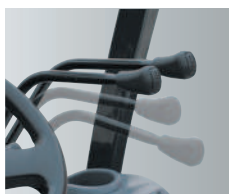

Control levers with contoured knobs for ease of control

A Smaller Steering Wheel Permits Widened Forward Visibility

Use of a smaller steering wheel and redesigned dashboard have improved the visibility to the bottom of the forks, thus enhancing the lifting function.

Steering wheel diameter: **11.8"**



Improved Braking Feel

Komatsu's unique cushioning valve enables control of the braking force in proportion to the pressure on the brake pedal and improves the braking feel.



KOMATSU EXCLUSIVE

Greater Operator Comfort and Reduced Fatigue in Even the Toughest Applications

Dual Floating Structure Reduces Vibrations

A unique dual vibration cushioning system reduces vibrations in the compartment, steering wheel, control levers and the mast. Any vibrations transmitted from the engine or road surface are quickly absorbed. The system is friendly to both the operator and the load.



● **Suspension cab**
The entire cab is isolated from the frame.

● **Floating Power Train**
The engine and transmission are isolated from the frame.

Full Suspension Seat for Improved Operator Comfort

The deluxe full suspension seat features improved vibration resistance and reduced stress on the body.

- Six-step reclining backrest
- 6.7" slide distance backward and forward
- Seat cushion adjustment dial
- Retractable seat belt



Reduced Exposure to Hot Air/Exhaust Gas When Driving in Reverse

Two counterweight air outlets are provided on the left and right sides and an exhaust pipe outlet is provided at a lower position so that the operator is not exposed to hot air from the radiator or to exhaust gasses when driving in reverse.



Exhaust outlet

Smooth Entry and Exit



Enlarged assist grip



Improved engine hood and wide open step design

The Low Noise Design

The low-noise design of the engine and the fully sealed floorboard area reduce offending noise during operation.

Clean Exhaust Air with a 3-Way Catalytic System (Gasoline)

The 3-way catalytic system purifies the nitrogen oxide (NOx), hydrocarbons (HC) and carbon monoxide (CO) emissions, in compliance with the latest EPA regulations.

Careful Designs Facilitate Easier Serviceability

Filter Layout Optimized for Improved Serviceability

A fully-opening floor plate.

Easy Radiator Cleaning

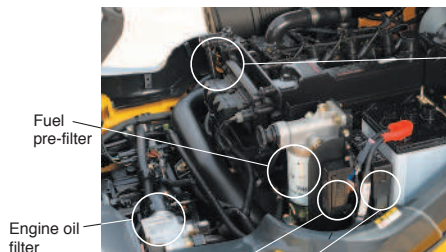
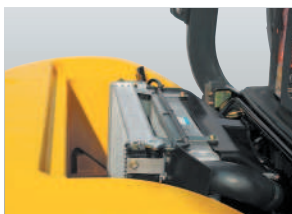

Fuel pre-filter

Engine oil filter

Fuel main filter

Locking engine hood provides protection while servicing

Fuse and relay boxes are arranged in the same location

Wide Opening Engine Hood with a Lock for Easy Servicing



Models



Compact model

This model is designed specifically for operating in tight spaces.



Standard model

This model is designed to perform a broad range of general-purpose applications.

LPG Specification Truck

LPG specification truck

Komatsu offers both single fuel (LPG) and optional dual fuel systems (LPG/Gasoline) for the LPG Specification truck.

Mast

2-stage free view mast

The mast enables a wide view with excellent forward visibility.

2-stage full free view mast

This is ideal for sites with height limitations, where maximum free lift is required.

3-stage free view mast

The mast extends in three stages and high level loading is easily performed.

Attachments

Side shifter

The forks may be shifted sideways together with its backrest, both to the right and to the left.

Fork positioner

The operator is able to adjust the fork spread width from the seated position.

Hinged fork

The fork tilts up/down using its hinge as a fulcrum.

Load stabilizer

The load is securely held from the top by the pressure plate of the load stabilizer.

Bale clamp

This attachment is recommended for handling packed pulp or raw cotton. The bale is efficiently held from both sides by the bale clamp.

Fork clamp

This attachment is effective for handling packed cotton and rough textile loads by grabbing them firmly from both sides.

Block clamp

This attachment can pick up concrete blocks without using pallets.

Rotating fork

Used together with the fork inserted container, this attachment is used for transporting items such as powder, fluids, etc. The fork is rotated in order to discharge the load.

Roll clamp

Rolls of paper or cylindrical objects are safely and securely handled by this attachment. It is possible to rotate the clamped load through 360 degrees.

Options

Engine & power train related

- Air intake pre-cleaner
- LPG swing down tank bracket

Exterior

- Steel cab
- Steel cab with heater & defroster
- Steel cab with air conditioner
- Tilt cylinder boots
- Rear view mirrors (pair)
- Wide Angle Center Mirror
- Fire extinguisher

Electrical equipment

- Back-up alarm
- Mast mounted head lights
- Rear working light
- Yellow strobe light
- Red strobe light

Meters & gauges

- Fuel level warning lamp

Tire-related

- Solid pneumatic tires
- Non-marking tires
- Dual front drive tires



Steel cab

Major equipment

●: Standard ○: Option -: N/A

		CX50 Series	
		Engine	Gasoline/ LPG
Closed-center Load Sensing System (CLSS)		●	●
Wet disc brake		●	●
Engine-related	EPA Tier 3/EU Stage IIIA compliant Diesel engine	●	-
	EPA compliant Gasoline engine	-	●
	Electronic engine control system	●	●
	Heavy duty High Pressure Common Rail system	●	-
	New combustion system	●	-
	Air to air charge air cooling system	●	-
	Overheat prevention function	●	-
	Auto engine warm-up function	●	-
	Auto air pre-heat function	●	-
	3-way catalytic system	-	●
Traveling-related	Large capacity radiator	●	●
	Dual floating structure	●	●
	New full suspension seat	●	●
	Small diameter steering wheel	●	●
	Tiltable steering column	●	●
	Electric forward/reverse lever	●	●
	Combination switch (turn signal light & light switch)	●	●
	Indicator auto-return mechanism	●	●
	Full-open step	●	●
	Paper binder at engine hood	●	●
Meters	Glove box at dashboard	●	●
	Meter panel	●	●
	Hourmeter (6-digit)	●	●
	Engine cooling water temperature gauge	●	●
Safety indicators	Fuel gauge	●	●
	Lifting interlock lamp	●	●
	Engine oil pressure warning lamp	●	●
	Charge warning lamp	●	●
	Neutral indicator	●	●
	Failure indicator	●	●
	Engine failure indicator	●	●
	Brake fluid pressure warning buzzer	●	●
Electric components	Fuel level warning lamp	○	○
	Glow indicator	●	-
	Large capacity alternator	●	●
	Quick auto glow system	●	-
	Neutral safety function	●	●
	Auto fuse	●	●
	Low maintenance battery	●	●
	Engine key stop function	●	-
Mechanism	Halogen headlight	●	●
	Rear combination light	●	●
	Back-up alarm	●	●
	KOPS Plus-"Komatsu Operator Presence System"	●	●
	Sedimenter with priming pump	●	-
	Cyclone air cleaner (double element)	●	●
	Parking brake with release button	●	●
	Fully hydrostatic power steering	●	●
Exterior	Non-asbestos parking brake linings	●	●
	Key-off lift lock	●	●
	Floor mat	●	●
	Assist grip	●	●
	Overhead guard with front/rear conduits	●	●
	Wide angle center mirror	○	○
	Rear view mirrors (pair)	○	○
	Full shield solid-state engine hood	●	●
	Easy-removable floor panel	●	●
	Easy-removable radiator cover	●	●
Engine hood lock	●	●	
Radiator reservoir tank	●	●	
Resin dashboard cover	●	●	
Jacking points	●	●	

CX50 Series Specifications

GENERAL		FG40ZTU-10	FD40ZTU-10	FG40TU-10			
Power Type	1	Gasoline	Diesel	Gasoline			
Operation Type	2	Sit-Down	Sit-Down	Sit-Down			
Capacity @ 24 in. (600 mm) load center *	lbs. (kg)	3	8,000 (3500)	8,000 (3500)	9,000 (4000)		
Load Distance - Front Axle Center to Fork Face	in. (mm)	4	21.3 (540)	21.3 (540)	22.8 (580)		
Wheelbase	in. (mm)	5	70.9 (1800)	70.9 (1800)	78.7 (2000)		
WEIGHT							
Service weight (includes 2-stage std. mast & forks)	lbs. (kg)	6	12,507 (5685)	12,617 (5735)	13,673 (6215)		
Axle Loading	Loaded	Front	lbs. (kg)	7	18,766 (8530)	18,865 (8575)	19,547 (8885)
		Rear	lbs. (kg)	8	2,541 (1155)	2,552 (1160)	2,926 (1330)
	Unloaded	Front	lbs. (kg)	9	4,873 (2215)	4,972 (2260)	5,555 (2525)
		Rear	lbs. (kg)	10	7,634 (3470)	7,645 (3475)	8,118 (3690)
TIRE							
Tire type	11	Pneumatic	Pneumatic	Pneumatic			
Tire size, front	12	250 - 15 - 16PR (I)	250 - 15 - 16PR (I)	300 - 15 - 18PR (I)			
Tire size, rear	13	7.00 - 12 - 12PR (I)	7.00 - 12 - 12PR (I)	7.00 - 12 - 12PR (I)			
Number of wheel, front / rear	x= driven	14	2x / 2	2x / 2	2x / 2		
Tread (center of tires)	Front	in. (mm)	15	43.9 (1115)	43.9 (1115)	45.3 (1150)	
	Rear	in. (mm)	16	44.1 (1120)	44.1 (1120)	44.1 (1120)	
DIMENSIONS							
Tilting angle, 2-stage (FV) masts, forward / backward	deg.	17	6 / 12	6 / 12	6 / 12		
Mast height, lowered (2-stage std. mast)	in. (mm)	18	82.7 (2100)	82.7 (2100)	106.7 (2710)		
Free lift height (2-stage std. mast)	in. (mm)	19	6.1 (155)	6.1 (155)	6.3 (160)		
Mast height, extended (2-stage std. mast) †	in. (mm)	20	162.6 (4130)	162.6 (4130)	162.6 (4130)		
Maximum fork height (2-stage std. mast) **	in. (mm)	21	118.1 (3000)	118.1 (3000)	118.1 (3000)		
Height overhead guard	in. (mm)	22	87.0 (2210)	87.0 (2210)	88.6 (2250)		
Length, with Std. Forks	in. (mm)	23	158.5 (4025)	158.5 (4025)	166.1 (4220)		
Length to fork face (2-stage mast)	in. (mm)	24	116.3 (2955)	116.3 (2955)	124.0 (3150)		
Overall width, at drive tires (single)	in. (mm)	25	53.1 (1350)	53.1 (1350)	57.1 (1450)		
Forks, thickness x width x length	in.	26	2.0 x 5.9 x 42.1	2.0 x 5.9 x 42.1	2.2 x 5.9 x 42.1		
Forks, thickness x width x length	mm	27	50 x 150 x 1070	50 x 150 x 1070	55 x 150 x 1070		
Carriage width / ITA Class	in. (mm)	28	46.9 (1190) / III	46.9 (1190) / III	46.9 (1190) / III		
Ground clearance, under mast	in. (mm)	29	5.5 (140)	5.5 (140)	5.7 (145)		
Ground clearance, center of wheelbase	in. (mm)	30	6.9 (175)	6.9 (175)	8.7 (220)		
Right angle stacking aisle ††	in. (mm)	31	122.9 (3120)	122.9 (3120)	131.9 (3350)		
Turning radius, outside	in. (mm)	32	101.6 (2580)	101.6 (2580)	109.1 (2770)		
PERFORMANCE							
Travel speed, forward, loaded - 1st / 2nd	mph (km/h)	33	11.2 (18.0) / NA	11.2 (18.0) / NA	11.2 (18.0) / NA		
Travel speed, forward, unloaded - 1st / 2nd	mph (km/h)	34	11.8 (19.0) / NA	11.8 (19.0) / NA	11.8 (19.0) / NA		
Lifting speed, loaded / unloaded (2-stage mast)	fpm (mm/s)	35	100.4 (510) / 100.4 (510)	106.3 (540) / 110.2 (560)	100.4 (510) / 100.4 (510)		
Lowering speed, loaded / unloaded (2-stage mast)	fpm (mm/s)	36	98.4 (500) / 98.4 (500)	98.4 (500) / 98.4 (500)	98.4 (500) / 98.4 (500)		
Maximum drawbar pull, loaded	lbs. (kN)	37	5,395 (24.0)	6,070 (27.0)	5,395 (24.0)		
Maximum gradability	%	38	28.0	30.0	25.0		
Service brake, operation/control		39	Foot / Hydraulic	Foot / Hydraulic	Foot / Hydraulic		
Parking brake, operation/control		40	Hand / Mechanical	Hand / Mechanical	Hand / Mechanical		
Steering, type		41	FHPS	FHPS	FHPS		
DRIVE							
Engine Manufacturer / Engine model		42	Nissan EBT-TB45-1A	Komatsu SAA4D95LE-5-A	Nissan EBT-TB45-1A		
Rated output (SAE Net)	HP (kW) @ rpm	43	83.8 (62.5) @ 2400	92.5 (69) @ 2250	92.5 (69) @ 2250		
Maximum torque (SAE Net)	lb-ft (Nm) @ rpm	44	201 (272) @ 1600	237 (321) @ 1600	201 (272) @ 1600		
No. of cylinders / displacement	cu. in. (cm3)	45	6 / 273 (4478)	4 / 199 (3260)	6 / 273 (4478)		
Fuel tank capacity	U.S. gallons (liters)	46	20.1 (76)	20.1 (76)	25.9 (98)		
OTHER							
Relief pressure, maximum	psi (bar)	47	2988 (206)	2988 (206)	2988 (206)		
Transmission		48	TORQFLOW	TORQFLOW	TORQFLOW		

NOTE: Most values shown in this publication are rounded. Therefore, direct conversion between metric and English or Imperial may be slightly different from those shown. The performance of the specifications shown here, discuss the proposed application with your authorized dealer.

*Optional masts, attachments, longer load dimensions, and higher lifting heights may result in downrating of the capacity. Contact your authorized dealer.

**Other mast heights available. See MAST DATA chart for other standard mast heights. Contact your authorized dealer.

†Includes 48-inch (1,220 mm) high load backrest. Contact your authorized dealer.

††Add Load Length Plus Clearance.

■Dimensions

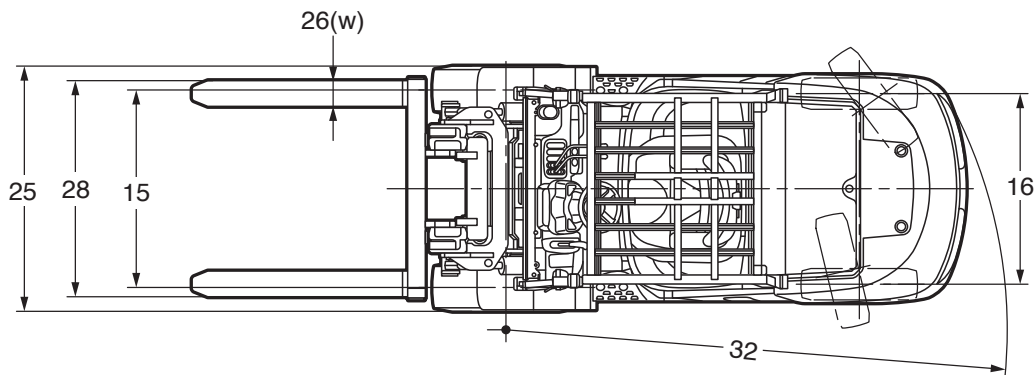

	FD40TU-10	FG45TU-10	FD45TU-10	FG50ATU-10	FD50ATU-10
	Diesel	Gasoline	Diesel	Gasoline	Diesel
	Sit-Down	Sit-Down	Sit-Down	Sit-Down	Sit-Down
	9,000 (4000)	10,000 (4500)	10,000 (4500)	11,000 (5000)	11,000 (5000)
	22.8 (580)	23.2 (590)	23.2 (590)	22.6 (575)	22.6 (575)
	78.7 (2000)	78.7 (2000)	78.7 (2000)	78.7 (2000)	78.7 (2000)
	13,794 (6270)	14,960 (6800)	15,081 (6855)	15,928 (7240)	16,049 (7295)
	19,624 (8920)	21,813 (9915)	21,890 (9950)	23,727 (10785)	23,804 (10820)
	2,970 (1350)	3,047 (1385)	3,091 (1405)	3,201 (1455)	3,245 (1475)
	5,632 (2560)	6,017 (2735)	6,094 (2770)	6,270 (2850)	6,347 (2885)
	8,162 (3710)	8,943 (4065)	8,987 (4085)	9,658 (4390)	9,702 (4410)
	Pneumatic	Pneumatic	Pneumatic	Pneumatic	Pneumatic
	300 - 15 - 18PR (I)	300 - 15 - 18PR (I)	300 - 15 - 18PR (I)	300 - 15 - 18PR (I)	300 - 15 - 18PR (I)
	7.00 - 12 - 12PR (I)	7.00 - 12 - 12PR (I)	7.00 - 12 - 12PR (I)	7.00 - 12 - 14PR (I)	7.00 - 12 - 14PR (I)
	2x / 2	2x / 2	2x / 2	2x / 2	2x / 2
	45.3 (1150)	45.3 (1150)	45.3 (1150)	45.3 (1150)	45.3 (1150)
	44.1 (1120)	44.1 (1120)	44.1 (1120)	44.1 (1120)	44.1 (1120)
	6 / 12	6 / 12	6 / 12	6 / 12	6 / 12
	106.7 (2710)	98.4 (2500)	101.8 (2585)	101.8 (2585)	101.8 (2585)
	6.3 (160)	5.7 (145)	5.7 (145)	5.7 (145)	5.7 (145)
	162.6 (4130)	162.6 (4130)	162.6 (4130)	171.1 (4345)	171.1 (4345)
	118.1 (3000)	118.1 (3000)	118.1 (3000)	118.1 (3000)	118.1 (3000)
	88.6 (2250)	88.6 (2250)	88.6 (2250)	88.6 (2250)	88.6 (2250)
	166.1 (4220)	168.1 (4270)	168.1 (4270)	173.4 (4405)	173.4 (4405)
	124.0 (3150)	126.0 (3200)	126.0 (3200)	125.4 (3185)	125.4 (3185)
	57.1 (1450)	57.1 (1450)	57.1 (1450)	57.1 (1450)	57.1 (1450)
	2.2 x 5.9 x 42.1	2.2 x 5.9 x 42.1	2.2 x 5.9 x 42.1	2.2 x 5.9 x 48.0	2.2 x 5.9 x 48.0
	55 x 150 x 1070	55 x 150 x 1070	55 x 150 x 1070	55 x 150 x 1220	55 x 150 x 1220
	46.9 (1190) / III	46.9 (1190) / III	46.9 (1190) / III	50.0 (1270) / IV	50.0 (1270) / IV
	5.7 (145)	5.7 (145)	5.7 (145)	5.7 (145)	5.7 (145)
	8.7 (220)	8.7 (220)	8.7 (220)	8.7 (220)	8.7 (220)
	131.9 (3350)	134.2 (3410)	134.2 (3410)	134.8 (3425)	134.8 (3425)
	109.1 (2770)	111.0 (2820)	111.0 (2820)	112.2 (2850)	112.2 (2850)
	11.2 (18.0) / NA	9.6 (15.5) / 14.3 (23.0)	9.0 (14.5) / 14.9 (24.0)	9.0 (14.5) / 14.6 (23.5)	9.0 (14.5) / 14.9 (24.0)
	11.8 (19.0) / NA	10.3 (16.5) / 14.9 (24.0)	9.6 (15.5) / 15.5 (25.0)	9.6 (15.5) / 15.2 (24.5)	9.6 (15.5) / 15.5 (25.0)
	106.3 (540) / 110.2 (560)	86.6 (440) / 86.6 (440)	92.5 (470) / 94.5 (480)	86.6 (440) / 86.6 (440)	92.5 (470) / 94.5 (480)
	98.4 (500) / 98.4 (500)	98.4 (500) / 98.4 (500)	98.4 (500) / 98.4 (500)	98.4 (500) / 98.4 (500)	98.4 (500) / 98.4 (500)
	6,070 (27.0)	6,295 (28.0)	7,419 (33.0)	6,295 (28.0)	7,419 (33.0)
	28.0	26.0	29.0	25.0	28.0
	Foot / Hydraulic	Foot / Hydraulic	Foot / Hydraulic	Foot / Hydraulic	Foot / Hydraulic
	Hand / Mechanical	Hand / Mechanical	Hand / Mechanical	Hand / Mechanical	Hand / Mechanical
	FHPS	FHPS	FHPS	FHPS	FHPS
	Komatsu SAA4D95LE-5-A	Nissan EBT-TB45-1A	Komatsu SAA4D95LE-5-A	Nissan EBT-TB45-1A	Komatsu SAA4D95LE-5-A
	92.5 (69) @ 2250	92.5 (69) @ 2250	92.5 (69) @ 2250	92.5 (69) @ 2250	92.5 (69) @ 2250
	237 (321) @ 1600	201 (272) @ 1600	237 (321) @ 1600	201 (272) @ 1600	237 (321) @ 1600
	4 / 199 (3260)	6 / 273 (4478)	4 / 199 (3260)	6 / 273 (4478)	4 / 199 (3260)
	25.9 (98)	25.9 (98)	25.9 (98)	25.9 (98)	25.9 (98)
	2988 (206)	2988 (206)	2988 (206)	2988 (206)	2988 (206)
	TORQFLOW	TORQFLOW	TORQFLOW	TORQFLOW	TORQFLOW

machines is affected by the condition of the truck and how it is equipped, as well as the nature and condition of the operating area. If these specifications are critical or if your needs exceed

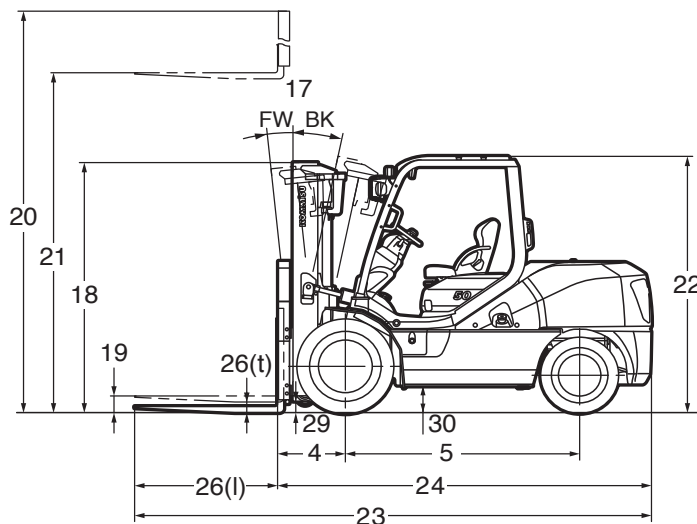

Building on our 80 year history of superior engineering, the CX50 delivers improved performance, unbeatable strength, greater reliability, and lower life-cycle costs while handling your most demanding applications.

CX50

PNEUMATIC TIRE FORKLIFTS

STRONG CUSTOMER SATISFACTION

Komatsu Forklift has a strong corporate commitment to produce, deliver and support quality products, and we have always made customer satisfaction our top priority. We will work to the best of our ability to help you maximize your operation's productivity while minimizing costs.

QUALITY PRODUCTS & SERVICES

Komatsu Forklift offers an expanding product line of over 120 electric and internal combustion engine forklift models with capacities from 2,000 to 35,000 pounds. We back them with a complete warranty program, superior service, and genuine OEM parts.

CONTACT YOUR DEALER TODAY

Your nearby Komatsu Forklift dealer is ready to assist you. Ask about financing and leasing programs that can be tailored to your business plan. Forklifts for your specific applications and workplace are waiting for you now.

KOMATSU DEALER NETWORK

Komatsu Forklift has over 195 dealer locations throughout the United States, Canada, Mexico, the Caribbean, and Central and South America. Komatsu dealers are staffed with dedicated teams of professionals who are trained to meet your forklift needs.

THE KOMATSU HERITAGE

As part of the Komatsu family, we have a proud heritage of excellence in equipment design and manufacturing. Since 1921 Komatsu has been a global leader in the construction and mining equipment industry. And since 1945, we have built upon that heritage by producing innovative, high-quality, durable forklifts to meet and exceed the needs of our customers.



KOM92-02

©2011 Komatsu America Corp.

Printed in USA

D11(500)OSP

11/11 (EV-1)

KOMATSU®

www.KomatsuAmerica.com

www.KomatsuForkliftUSA.com

Komatsu America Corp. is an authorized licensee of Komatsu Ltd. Materials and specifications are subject to change without notice. Photos may include optional equipment.

KOMATSU is a registered trademark of Komatsu Ltd., Japan
Courtesy of CraneMarket